

STUDENT NAME _____

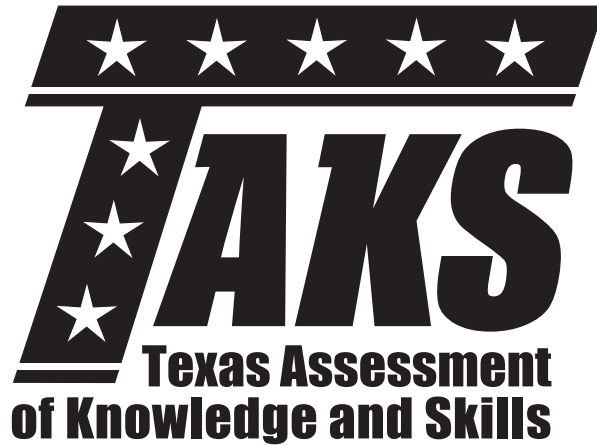

**GRADE 7
WRITING
MATHEMATICS
READING**

Administered Spring 2006

WRITTEN COMPOSITION

Write a composition about your favorite memory.

The information in the box below will help you remember what you should think about when you write your composition.

REMEMBER—YOU SHOULD

- write about your favorite memory
- make your writing interesting to the reader
- make sure that each sentence you write helps the reader understand your composition
- make sure that your ideas are clear and easy for the reader to follow
- write about your ideas in detail so that the reader really understands what you are saying
- check your work for correct spelling, capitalization, punctuation, grammar, and sentences

USE THIS PREWRITING PAGE TO
PLAN YOUR COMPOSITION.

MAKE SURE THAT YOU WRITE YOUR COMPOSITION ON
THE TWO LINED PAGES IN THE ANSWER DOCUMENT.

USE THIS PREWRITING PAGE TO
PLAN YOUR COMPOSITION.

MAKE SURE THAT YOU WRITE YOUR COMPOSITION ON
THE TWO LINED PAGES IN THE ANSWER DOCUMENT.

USE THIS PREWRITING PAGE TO
PLAN YOUR COMPOSITION.

MAKE SURE THAT YOU WRITE YOUR COMPOSITION ON
THE TWO LINED PAGES IN THE ANSWER DOCUMENT.

Revising and Editing Sample

DIRECTIONS

Read the introduction and the passage that follows. Then read each question and fill in the correct answer on page 2 of your answer document.

Jesse wrote this paper for his science class. He has asked you to help him decide how to correct and improve it. Read Jesse's paper. Then answer the questions that follow.

The Mystery of Migration

(1) Scientists have learned many facts about the animals that live on our planet. (2) However, one thing remains quiet puzzling. (3) How does the process of migration work? (4) Scientists know that animals migrate to find food. (5) They also migrate to give birth. (6) Humpback whales, for example, usually live in the icy waters of the Arctic and the Antarctic, but when it comes time to have their babies, they move to the warmer waters near the equator.

S-1 What change, if any, should be made in sentence 2?

- A** Delete the comma after *However*
- B** Change *remains* to **remain**
- C** Change *quiet* to **quite**
- D** Make no change

S-2 What is the BEST way to combine sentences 4 and 5?

- F** Scientists know that animals migrate to find food, they also migrate to give birth.
- G** Scientists know that to find food and migrate, animals give birth.
- H** Scientists know this, animals migrate to find food and give birth.
- J** Scientists know that animals migrate to find food or give birth.



REVISING AND EDITING

DO NOT GO ON TO THE REVISING AND EDITING SECTION.
WHEN YOU FINISH YOUR COMPOSITION, RAISE YOUR HAND
AND WAIT FOR A TEST ADMINISTRATOR TO ASSIST YOU.

DIRECTIONS

Read the following passages and mark your answers on page 2 of your answer document. Remember that you are NOT permitted to use dictionaries or other reference materials on this section of the test.

Ivan read a newspaper article about an unusual event. He wrote this paper to tell about the event. He would like you to read his rough draft and suggest corrections and improvements. After you finish reading, answer the questions that follow.



Photo courtesy of © Reuters/CORBIS.

Out-of-This-World Wedding

(1) In some ways it was just like any other wedding. (2) The bride wore a tradition wedding gown and was surrounded by family and friends. (3) In other ways, however, this wedding was very different. (4) The groom was wearing a blue flight suit and 240 miles above Earth on the International Space Station floating.

(5) On August 10, 2003, Ekaterina Dmitriev married Russian cosmonaut Yuri Malenchenko in the world's first space wedding. (6) The

ceremony took place during a live video link between the Johnson space center in Houston and the International Space Station. (7) There is a great movie that tells about life aboard the space station. (8) The couple had wanted to get married in the same room, but when Malenchenko's mission was extended, they decided not to wait for his return.

(9) The meeting room at the space center was decorated to look like a wedding chapel. (10) Malenchenko and his crewmate Edward Lu, the best man, appeared on a giant video screen. (11) Lu played the "Wedding March." (12) He used a portable keyboard. (13) The bride and groom each placed a wedding ring on their own finger. (14) The ceremony ended with Dmitriev and Malenchenko blowing each other a kiss.

(15) After the private ceremony the bride and the wedding party they attended a reception at a restaurant. (16) The restaurant was adorned with stars and astronaut statues. (17) Before entering the reception, Dmitriev spoke with reporters. (18) Standing next to a life-size cardboard cutout of her groom, she told reporters that their long-distance relationship had brought her and Malenchenko closer. (19) She then grabbed the cardboard cutout and said, "I'm taking him with me."

1 What change, if any, should be made in sentence 2?

- A Change *tradition* to **traditional**
- B Insert a comma after *gown*
- C Change *surrounded* to **surounded**
- D Make no change

2 What is the BEST way to revise sentence 4?

- F The groom, who was wearing a blue flight suit, he was floating 240 miles above Earth on the International Space Station.
- G The groom wearing a blue flight suit, he was floating 240 miles above Earth on the International Space Station.
- H The groom was wearing a blue flight suit. Floating 240 miles above Earth on the International Space Station.
- J The groom was wearing a blue flight suit and floating 240 miles above Earth on the International Space Station.

3 What change, if any, should be made in sentence 6?

- A Change *took* to **taking**
- B Change *during* to **durring**
- C Change *Johnson space center* to **Johnson Space Center**
- D Make no change

4 What revision, if any, is needed in sentence 8?

- F The couple had wanted to get married in the same room, but when Malenchenko's mission was extended. They decided not to wait for his return.
- G The couple had wanted to get married in the same room, Malenchenko's mission was extended, they decided not to wait for his return.
- H The couple had wanted to get married in the same room when Malenchenko's mission was extended. And decided not to wait for his return.
- J No revision is needed.

5 What change, if any, should be made in sentence 9?

- A Insert **it** after *center*
- B Change *decoratted* to **decorated**
- C Change *wedding chapel* to **Wedding Chapel**
- D Make no change

- 6 What is the BEST way to combine sentences 11 and 12?
- F Lu played the “Wedding March” that used a portable keyboard.
 - G Lu played the “Wedding March,” he used a portable keyboard.
 - H Lu played the “Wedding March” and a portable keyboard.
 - J Lu played the “Wedding March” on a portable keyboard.

- 7 What change, if any, should be made in sentence 15?
- A Delete *they*
 - B Change *attended* to **will attend**
 - C Change *reception* to **recepshion**
 - D Make no change

- 8 What change, if any, should be made in sentence 19?
- F Change *grabbed* to **grabed**
 - G Delete the comma
 - H Insert quotation marks before *I’m*
 - J Make no change

- 9 Which sentence does NOT belong in this paper?
- A Sentence 1
 - B Sentence 7
 - C Sentence 13
 - D Sentence 14

Isabelle wrote this report about paper money. Read Isabelle's report and think of ways she should correct and improve it. When you finish, answer the questions that follow.



Photo courtesy of © Alan Schein Photography/CORBIS.

Paper Money

- (1) In this country we use both coins and paper money to purchase things. (2) There are many interesting facts about the paper money we use. (3) First of all, it isn't actually made from regular paper. (4) It is made from a blend of cotton and linen. (5) That's why a dollar bill doesn't fall apart when it accidentally takes a spin in a washing machine. (6) You would have to fold a dollar bill 4,000 times, first forward and then backward, before it would tear. (7) As sturdy as paper money is, it eventually wears out and have to be replaced. (8) The time it takes for this to happen is not the same for

all bills. (9) A one-dollar bill may circulate for just 22 months because it is handled so frequently. (10) A hundred-dollar bill, the largest bill used today could last as long as nine years because it is used less often.

(11) You may wonder what happens to money when it finally does wear out. (12) The bureau of engraving and printing is the agency responsible for printing U.S. money. (13) It is also this agency's job to collect and replace damaged money. (14) The old money is shredded, and the old money is then used in a variety of ways. (15) Students at one university are working to find ways to recycle old money and use it in products such as filters and vacuum-cleaner bags. (16) Some artists have used shredded money in special exhibits. (17) Artists are creative people. (18) One company even sells shredded money. (19) It puts the pieces in bags or bottles. (20) People can buy a bag of shredded money for a fraction of its original value.

(21) As you can see, there is a lot to learn about the money we use.

(22) You can look on the Internet to learn even more.

10 What change, if any, should be made in sentence 2?

- F Change *are* to **is**
- G Change *intresting* to **interesting**
- H Insert a comma after *facts*
- J Make no change

11 Which transition word or phrase could BEST be added to the beginning of sentence 6?

- A Afterward,
- B Finally,
- C In fact,
- D In comparison,

12 What change should be made in sentence 7?

- F Change *sturdy* to **sturdey**
- G Delete the comma
- H Change *wears* to **worn**
- J Change *have to be replaced* to **has to be replaced**

13 What change, if any, should be made in sentence 10?

- A Change *largest* to **larger**
- B Insert a comma after *today*
- C Delete *because*
- D Make no change

14 What change, if any, should be made in sentence 12?

- F Change *bureau of engraving and printing* to **Bureau of Engraving and Printing**
- G Delete *is*
- H Change *responsible* to **responsibly**
- J Make no change

15 What is the BEST way to revise sentence 14?

- A The old money is shredded, it is then used in a variety of ways.
- B The old money is shredded. To be then used in a variety of ways.
- C The old money is shredded and then used in a variety of ways.
- D The old money, which is shredded in a variety of ways, it is then used.

16 Which sentence does NOT belong in this paper?

- F Sentence 11
- G Sentence 16
- H Sentence 17
- J Sentence 18

GO ON TO THE NEXT PAGE

Matt wrote this story about a memorable experience. He would like you to read his paper and think about the corrections and improvements he should make. When you finish, answer the questions that follow.



Photo courtesy of © Michael T. Sedam/CORBIS.

Up, Up, and Away!

(1) In October my family and I took a trip to the International Balloon Fiesta in Albuquerque, New Mexico. (2) I had never seen so many hot-air balloons in my life. (3) We saw balloons in a wide variety of shapes, including a cow, a shoe, and a motorcycle! (4) But the best part of our trip was when we went for a ride in a hot-air balloon.

(5) We arrived early in the morning to help the crew get it off the ground. (6) First we unrolled the envelope, the colored part of the

balloon. (7) Then the pilot connected the envelope to the burner and basket. (8) An assistant brought out a very, very big fan. (9) I held the mouth of the envelope open while the fan blasted air into it. (10) When the balloon looked about half-full we stood aside so that the pilot could ignite the burner. (11) The fan continued adding air, and the burner kept heating it. (12) Because hot air rises, the balloon started to go up. (13) The crew held the basket down while my family and I climbed into it. (14) We were off!

(15) I felt like a bird soaring graceful above the city. (16) As my sister and I looked down, we thought the houses looked just like dollhouses. (17) The pilot explained that he could steer the balloon by adjusting its height to catch different air currents. (18) I was fascinated. (19) I could have stayed up in the air forever! (20) But eventually it was time to return to Earth. (21) The pilot let me pull a cord that opened a flap in the top of the balloon. (22) The hot air escaped, the balloon began to sink slowly. (23) Suddenly I felt a bump. (24) We skidded to a stop on the ground. (25) The ride was over, but when I close my eyes, I can still remember what it felt like to be lighter than air.

- 17 The meaning of sentence 5 can be improved by changing **it** to —
- A the balloon
 - B the trip
 - C them
 - D the shapes
- 18 What change, if any, should be made in sentence 8?
- F Change **assistant** to **assistent**
 - G Change **brought** to **brings**
 - H Change **a very, very big** to **an enormous**
 - J Make no change
- 19 What change, if any, should be made in sentence 10?
- A Change **looked** to **looks**
 - B Insert a comma after **half-full**
 - C Change **we** to **you**
 - D Make no change
- 20 Which sentence could BEST follow sentence 13?
- F I guess this was another part of their job.
 - G They had to hold the basket down until everyone had climbed in.
 - H When everyone was settled, the workers released the basket.
 - J I was wearing a jacket because it was a little cool that morning.
- 21 What change, if any, should be made in sentence 15?
- A Change **soaring** to **to soar**
 - B Change **graceful** to **gracefully**
 - C Change **the city** to **it**
 - D Make no change
- 22 What revision, if any, is needed in sentence 22?
- F As the hot air escaped, the balloon began to sink slowly.
 - G The hot air escaping. And the balloon began to sink slowly.
 - H Because the hot air escaped. The balloon began to sink slowly.
 - J No revision is needed.
- 23 What change should be made in sentence 25?
- A Change **rember** to **remember**
 - B Change **felt** to **feeled**
 - C Change **lighter** to **more lighter**
 - D Change **than** to **then**

GO ON TO THE NEXT PAGE

Margaret read an article about a man who competed in a unique race. She wrote this paper and would like you to read it. As you read, think about the corrections and improvements that Margaret should make. When you finish, answer the questions that follow.



Photo courtesy of © www.maxranchi.com.

Sailing Solo

(1) Tim Kent began sailing as an 11-year-old in Milwaukee, Wisconsin. (2) As he sailed on the Great Lakes in those days, he had no idea that he would one day sail around the entire world. (3) However, in 2003, at the age of 50, Kent did just that. (4) Even though he was up against some of the world's most experienced sailors, Kent managed to earn second place in a seven-month race around the world.

(5) For more than 20 years, sailors have competed in a race called Around Alone. (6) It is a boat race. (7) It is sometimes called the Mount

Everest of sailing. (8) Interested sailors come to New York to begin the competition. (9) Each participant must sail around the entire world alone. (10) Encompassing almost 29,000 miles, the trip is not easy. (11) Sailors face menacing waves, strong winds, and unpredictable weather. (12) They also have to cope with both sweltering and frigid temperatures. (13) With no one else to rely on for help, Around Alone competitors must often stay awake for long periods of time to make sure they are on course and out of danger.

(14) Kent's journey went good. (15) He was equipped with two types of radar to warn other boats that he was approaching. (16) He checked with a laptop computer that he had for checking electronic charts and weather maps. (17) Kent also used his computer to communicate with his two young daughters in Wisconsin, as well as with the many students across the United States who were following his travels on the Internet. (18) He brought along other communication devices too, including a satellite phone for emergencies. (19) I'm sure it was much more reliable than a cell phone.

(20) When he finished the race, Kent was greeted by cheers from a welcoming crowd that included their two daughters. (21) Before starting on the trip, he had said, "The stars are aligned to make the dream a reality now." (22) Tim Kent's smile proved that his dream had come true.

- 24 What is the BEST way to combine sentences 5 and 6?
- F For more than 20 years, sailors have competed in a race called Around Alone, it is a boat race.
 - G For more than 20 years, sailors competing in a boat race called Around Alone.
 - H For more than 20 years, sailors have competed and in a race called Around Alone, a boat race.
 - J For more than 20 years, sailors have competed in a boat race called Around Alone.

- 25 What change, if any, should be made in sentence 8?
- A Change *Interested* to **Intrested**
 - B Change *new york* to **New York**
 - C Change *the competition* to **it**
 - D Make no change

- 26 What change, if any, should be made in sentence 14?
- F Change *Kent's* to **Kents'**
 - G Change *journey* to **journy**
 - H Change *good* to **well**
 - J Make no change

- 27 What is the BEST way to rewrite the idea in sentence 16?
- A He had a laptop computer for checking electronic charts and weather maps.
 - B He checked electronic charts and weather maps. With a laptop computer that he had.
 - C He had a laptop computer, he checked electronic charts and weather maps with it.
 - D He checked with a laptop computer. That he had for checking electronic charts and weather maps.

28 What change should be made in sentence 17?

- F Insert a comma after *computer*
- G Change *communicate* to *communicate*
- H Change *students* to *students'*
- J Change *was following* to *were following*

29 What change, if any, should be made in sentence 20?

- A Change *welcoming* to *welcomming*
- B Change *that* to *it*
- C Change *their* to *his*
- D Make no change

30 What change, if any, should be made in sentence 21?

- F Delete the comma after *said*
- G Insert quotation marks before *The*
- H Change the period to a comma
- J Make no change

31 Which sentence does NOT belong in this paper?

- A Sentence 3
- B Sentence 9
- C Sentence 19
- D Sentence 22

In this paper Traci tells her version of a Native American tale that teaches a lesson. She would like you to read her paper and look for the corrections and improvements that she needs to make. Then answer the questions that follow.

Why Possum's Tail Is Bare

(1) Long ago, Possum had a bushy tail. (2) He carried it high, looking around to make sure the other animals noticed his fine dark fur.

(3) Possum thought that he was very special.

(4) Whenever Possum passed Rabbit, he would speak in a superior tone. (5) "I'm sorry," he would say, "that your tail is just a little puff.

(6) I hope the sight of my fine, bushy backside doesn't embarrass you."

(7) Then he would move on, he would swish his tail in Rabbit's angry face.

(8) When feast day arrived, Rabbit delivered invitations to all the animals in the forest. (9) Of course, he found Possum grooming his tail.

(10) "Will you be able to attend the feast," Rabbit asked.

(11) Possum nodded, saying, "It would be selfish to keep my glorious tail out of sight." (12) Then he cast a look of pity at Rabbit's little tail.

(13) Rabbit's blood boiled!

(14) Later that day Rabbit visited Cricket. (15) Annoyed by Possum's bragging, the two friends came up with a plan.

(16) Cricket was well known as an expert hairstylist. (17) When she offered to style Possum's tail, he was thrilled. (18) He dozed. (19) Cricket

combed and clipped. (20) Finally Cricket stood back as if to admire her work. (21) “I’m going to protect your beautiful tail with this red scarf,” she said. (22) “You can untie it at the feast when the dancing begin.”

(23) At that evening’s feast the drums began to beat. (24) Possum loosened the scarf, and Possum leaped onto the dance floor. (25) He flicked his tail, but there was no familiar whoosh of wind from waving fur. (26) Instead, his backside felt cold. (27) Suddenly they heard the other animals laughing. (28) At that point Possum realized that his tail was complete bald! (29) He was so embarrassed that he rolled over and pretended to be dead.

32 What change, if any, should be made in sentence 2?

- F** Change *He carried* to **Carrying**
- G** Change *notised* to **noticed**
- H** Change *his* to **their**
- J** Make no change

33 What revision, if any, is needed in sentence 7?

- A** Then he would move on, swishing his tail in Rabbit’s angry face.
- B** Then he would move on. Swishing his tail in Rabbit’s angry face.
- C** Then he would move on and swish in Rabbit’s angry face his tail.
- D** No revision is needed.

- 34** What change, if any, should be made in sentence 10?
- F** Change *you* to *yours*
 - G** Change *attend* to *atend*
 - H** Change the comma to a question mark
 - J** Make no change

- 35** What is the BEST way to combine sentences 18 and 19?
- A** He dozed because Cricket combed and clipped.
 - B** He dozed as Cricket combed and clipped.
 - C** He dozed, Cricket combed and clipped.
 - D** He dozed, combed, and clipped Cricket.

- 36** What change, if any, should be made in sentence 22?
- F** Change *it* to *them*
 - G** Insert a semicolon after *feast*
 - H** Change *begin* to *begins*
 - J** Make no change

- 37** What is the BEST way to revise sentence 24?
- A** Possum loosened the scarf and leaped onto the dance floor.
 - B** Possum loosened the scarf, he leaped onto the dance floor.
 - C** Possum loosened the scarf. And leaped onto the dance floor.
 - D** Possum loosened the scarf that leaped onto the dance floor.

38 What change should be made in sentence 27?

- F Change *Suddenly* to **Suddenley**
- G Change *they* to **he**
- H Change *heard* to **herd**
- J Change *laughing* to **laughed**

40 Which sentence could BEST be added after sentence 29?

- F When he rolled over, he was just pretending to be dead.
- G A possum carries its young in its pouch or on its back.
- H I saw a possum do this one time in the woods behind my house.
- J To this day possums everywhere roll over and play dead when they are upset.

39 What change, if any, should be made in sentence 28?

- A Change *realized* to **relized**
- B Change the second *that* to **it**
- C Change *complete* to **completely**
- D Make no change

BE SURE YOU HAVE RECORDED ALL OF YOUR ANSWERS
ON THE ANSWER DOCUMENT.



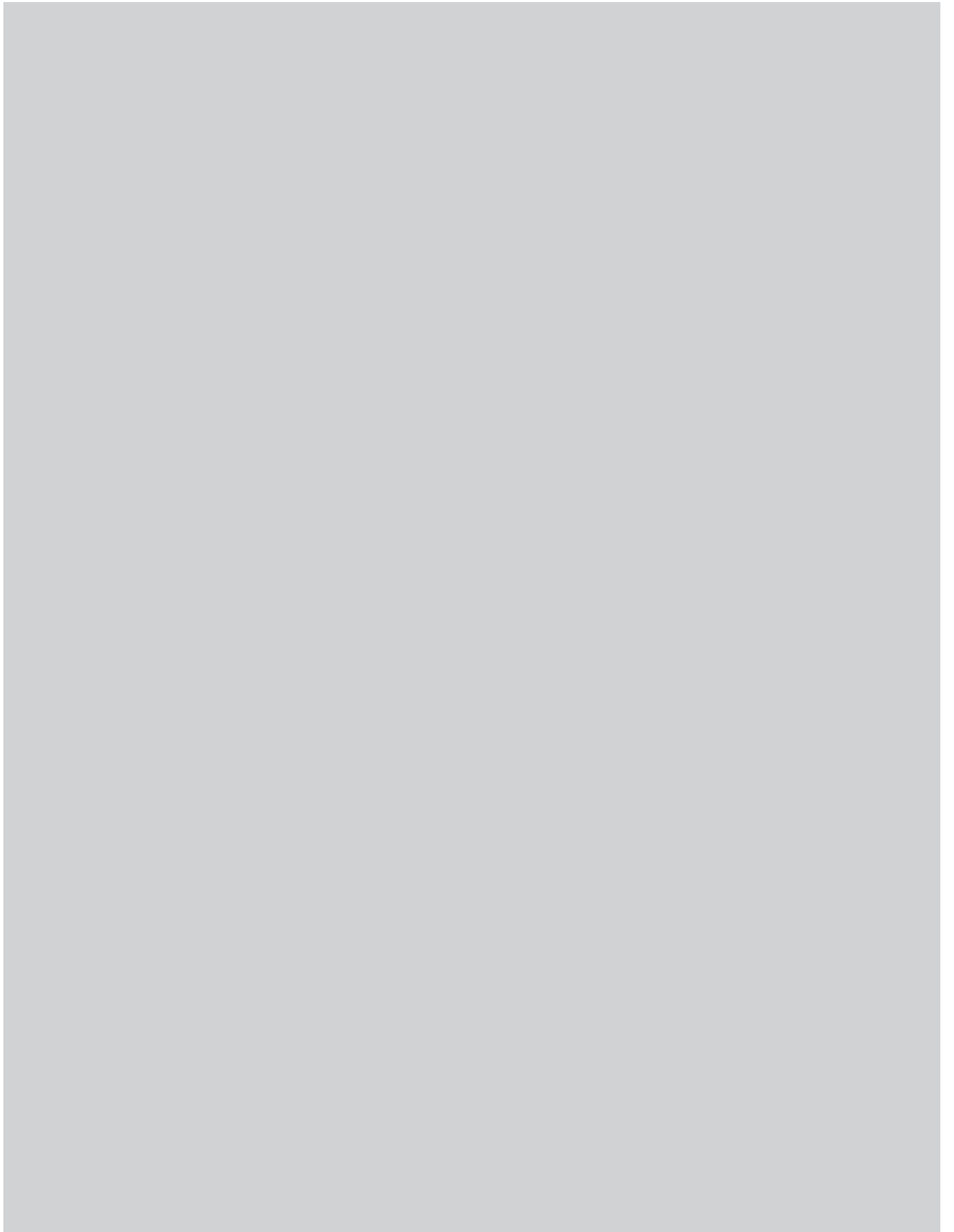

MATHEMATICS

Mathematics Chart

LENGTH

Metric

1 kilometer = 1000 meters
1 meter = 100 centimeters
1 centimeter = 10 millimeters

Customary

1 mile = 1760 yards
1 mile = 5280 feet
1 yard = 3 feet
1 foot = 12 inches

CAPACITY AND VOLUME

Metric

1 liter = 1000 milliliters

Customary

1 gallon = 4 quarts
1 gallon = 128 ounces
1 quart = 2 pints
1 pint = 2 cups
1 cup = 8 ounces

MASS AND WEIGHT

Metric

1 kilogram = 1000 grams
1 gram = 1000 milligrams

Customary

1 ton = 2000 pounds
1 pound = 16 ounces

TIME

1 year = 365 days
1 year = 12 months
1 year = 52 weeks
1 week = 7 days
1 day = 24 hours
1 hour = 60 minutes
1 minute = 60 seconds

Metric and customary rulers can be found on the separate Mathematics Chart.

Mathematics Chart

Perimeter	square	$P = 4s$
	rectangle	$P = 2l + 2w$ or $P = 2(l + w)$
Circumference	circle	$C = 2\pi r$ or $C = \pi d$
Area	square	$A = s^2$
	rectangle	$A = lw$ or $A = bh$
	triangle	$A = \frac{1}{2}bh$ or $A = \frac{bh}{2}$
	trapezoid	$A = \frac{1}{2}(b_1 + b_2)h$ or $A = \frac{(b_1 + b_2)h}{2}$
	circle	$A = \pi r^2$
Volume	cube	$V = s^3$
	rectangular prism	$V = lwh$ or $V = Bh^*$
	cylinder	$V = \pi r^2h$ or $V = Bh^*$
<i>*B represents the area of the Base of a solid figure.</i>		
Pi	π	$\pi \approx 3.14$ or $\pi \approx \frac{22}{7}$

DIRECTIONS

Read each question. Then fill in the correct answer on your answer document. If a correct answer is not here, mark the letter for “Not here.”

SAMPLE A

Find the greatest common factor of 12 and 18.

- A 3
- B 6
- C 9
- D Not here

SAMPLE B

Find the perimeter of this square rug in meters.

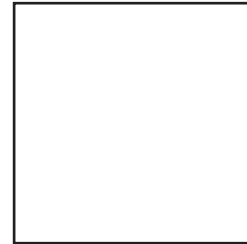

3.2 m

Record your answer and fill in the bubbles on your answer document. Be sure to use the correct place value.



1 Max drew a triangle on the coordinate plane shown below.

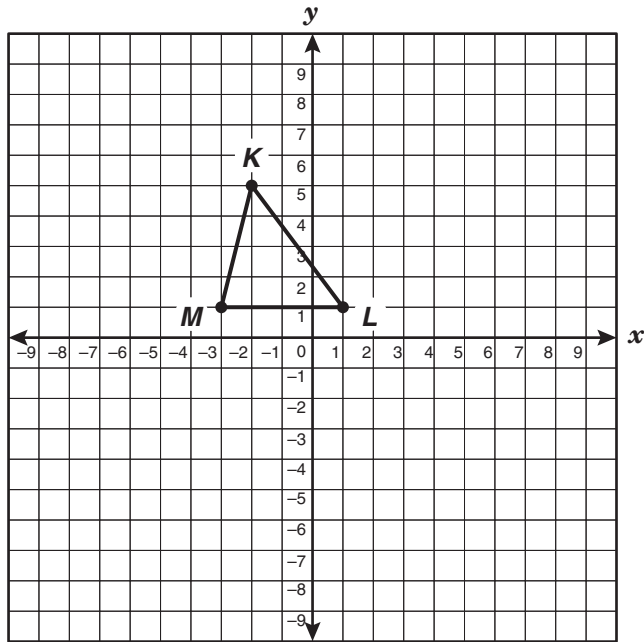

Which of the following best represents the coordinates of the vertices of $\triangle KLM$?

- A $(-2, 5), (1, 1), (-3, 1)$
- B $(-2, 5), (1, 1), (1, -3)$
- C $(5, -2), (1, 1), (1, -3)$
- D $(5, -2), (1, 1), (-3, 1)$

- 2** The numbers in Set R share a common characteristic.

Set R: 48, 54, 6, 66, 12, 24

The numbers in Set S do not share this characteristic.

Set S: 9, 20, 39, 15, 63, 27, 44

Which best describes the characteristic that only the numbers in Set R share?

- F** Numbers less than 70
- G** Numbers greater than 5
- H** Numbers that are composite
- J** Numbers divisible by 6

- 3** Leon bought a dozen daisies for \$3.75. Which is closest to the amount Leon paid for each daisy?

- A** \$0.25
- B** \$0.29
- C** \$0.31
- D** \$0.38

4 The top, front, and side views of a solid figure made of cubes are shown below.

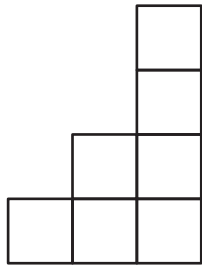

Top

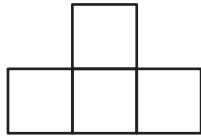

Front

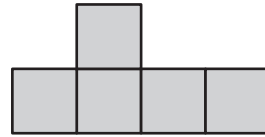

Side

Which solid figure is best represented by these views?

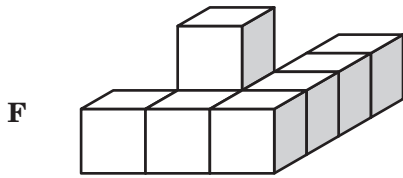

Front

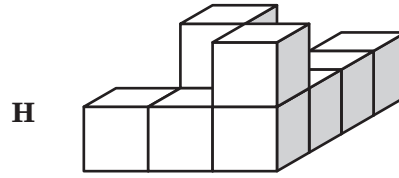

Front

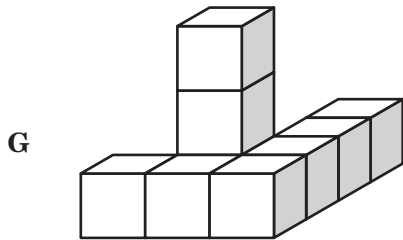

Front

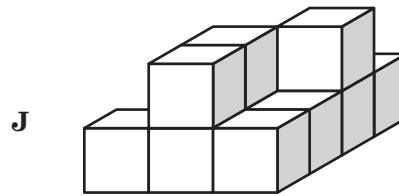

Front

- 5 Which rule can be used to find the value of any term in the sequence below where n represents the position of the term?

Position	Value of Term
1	6
2	10
3	14
4	18
5	22
n	

- A $2n + 4$
B $4n + 2$
C $3n + 3$
D $8n - 2$
- 6 A farmer knows the length and width of his rectangular pasture. He also knows how many pounds of fertilizer to spread per square yard. What additional information does the farmer need to know in order to determine the number of bags of fertilizer he should buy?
- F The type of grass in his pasture
G The number of bags of fertilizer his truck will hold
H The price of each bag of fertilizer
J The number of pounds of fertilizer in each bag

- 7 Which situation is best represented by the equation $x - 4 = 16$?

- A Miranda picked 16 apples and ate $\frac{1}{4}$ of them. What is x , the number of apples she had left?
B Felipe ran for 16 minutes and walked for 4 minutes. What is x , the difference between the time he spent running and the time he spent walking?
C Jordan spent \$4 of his allowance and had \$16 left. What is x , the total amount of Jordan's allowance?
D Cecilia has hit 4 of the last 16 balls pitched. What is x , the total number of balls pitched?

- 8 Marilou needs to cut a piece of glass for her table. The table is in the shape of a regular hexagon. The glass should measure $1\frac{1}{2}$ feet on each side. What is the perimeter of the piece of glass?

- F 12 ft
G 9 ft
H 18 ft
J 7.5 ft

- 9 Look at the 2 rectangles below.

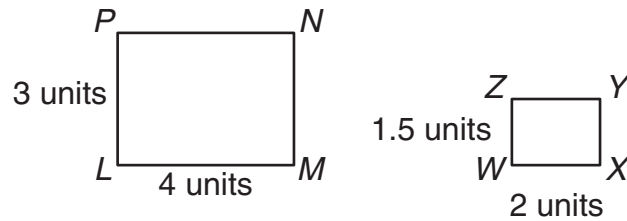

Which method could be used to prove that the rectangles are similar?

- A Divide 3 by 2 and 4 by 1.5 to see whether the quotients are the same
- B Divide 1.5 by 4 and 2 by 3 to see whether the quotients are the same
- C Divide 4 by 1.5 and 2 by 3 to see whether the quotients are the same
- D Divide 3 by 1.5 and 4 by 2 to see whether the quotients are the same
-
- 10 Lynne works at a bank and earns \$9.75 per hour. If Lynne works 35 hours each week, which expression could be used to determine her total earnings for 1 year?
- F 9.75×35
- G 9.75×52
- H $9.75 \times 35 \times 52$
- J $9.75 \times 35 \times 12$

- 11 The equation $3x + 3 = x + 9$ is modeled below.

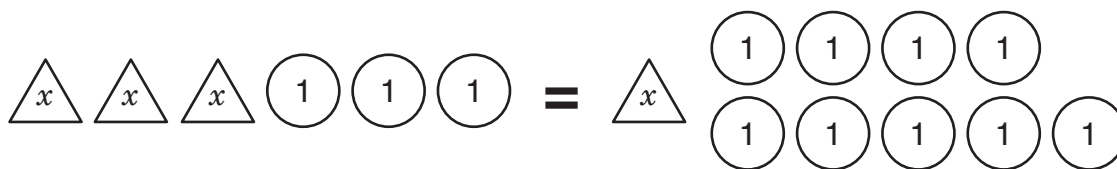

What value of x makes the equation true?

- A $x = 3$
 - B $x = 6$
 - C $x = 12$
 - D $x = 4$
-
- 12 DeAndre bought 15 party hats priced at 3 for \$0.65 and 56 noisemakers priced at 7 for \$1.25. What was the total cost of the hats and noisemakers, not including tax?
- F \$9.75
 - G \$8.75
 - H \$10.70
 - J \$13.25

- 13 Beatrice translated trapezoid $RSTU$ to trapezoid $R'S'T'U'$. Vertex S was at $(4, 1)$.

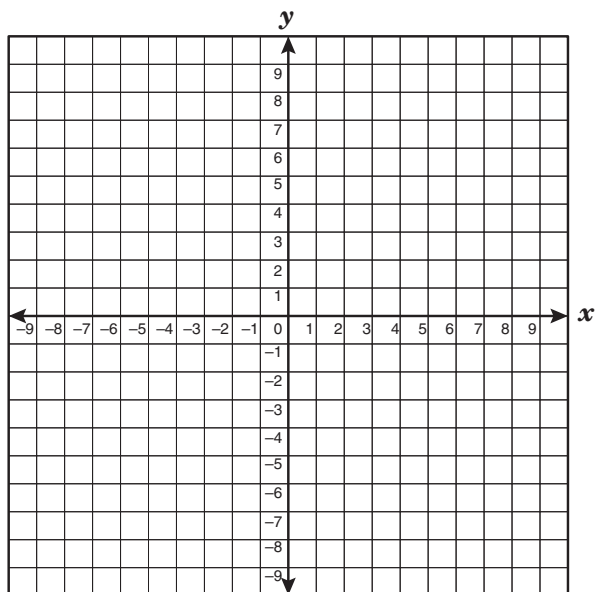

If vertex S' is at $(-3, 4)$, which best describes this translation?

- A Move 7 units left and 3 units up
 B Move 1 unit left and 3 units up
 C Move 3 units down and 7 units right
 D Move 8 units left and 4 units up
- 14 A triangle with two congruent sides and an angle of 104° is —
- F isosceles and right
 G isosceles and obtuse
 H isosceles and acute
 J scalene and obtuse

- 15 Laneitre is trying to figure out the heights of 3 people. Here are the facts she knows.

- The sum of the heights of these 3 people is 17 feet 5 inches.
- The shortest person is 5 feet 4 inches tall.
- The other 2 people differ in height by 3 inches.

How tall is the tallest person?

- A 5 feet 4 inches
 B 5 feet 11 inches
 C 6 feet 2 inches
 D 12 feet 1 inch
- 16 Brenda wants to attach a string of beads along the circular bottom edge of the lamp shade shown below. The diameter of the bottom of the lamp shade is 16 centimeters.

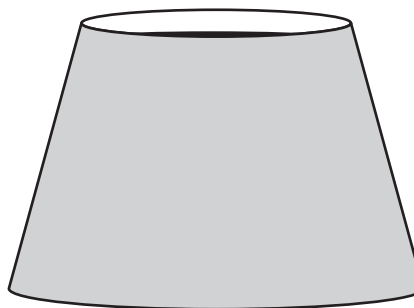

About how many centimeters long should Brenda make the string of beads?

- F 25 cm
 G 50 cm
 H 79 cm
 J 201 cm

- 17 The drawing below shows the rotor of a helicopter.

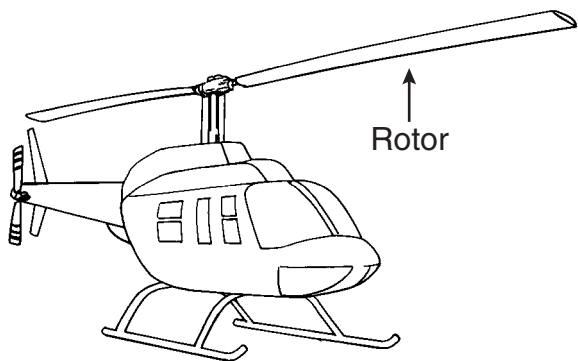

This helicopter has a rotor that moves at a rate of 500 spins per minute while flying. Which statement is best supported by this information?

- A The helicopter rotor will spin 2,000 times in 40 minutes.
- B The helicopter rotor will spin 4,000 times before lifting the helicopter off the ground.
- C The helicopter rotor will spin 15,000 times in 3 hours.
- D The helicopter rotor will spin 30,000 times in 1 hour.

- 18 Mrs. Newsome said that $\frac{1}{8}$ of the faculty at Long High School had attended the school as teenagers. Which decimal and percent are equivalent to $\frac{1}{8}$?

- F 0.18, 18%
- G 0.125, 12.5%
- H 1.8, 180%
- J 1.25, 125%

- 19 Arthur uses his own tractor while doing various jobs. He is paid a flat fee of \$100 for each job. In addition to the flat fee, he is paid \$20 for each hour he works with the tractor. Which shows how to find the amount Arthur should be paid for working with the tractor for 10 hours?

- A Add 20 to 10 and then multiply the sum by 100
- B Multiply 100 by 10 and then add 20 to the product
- C Multiply 20 by 10 and then add 100 to the product
- D Add 20 to 100 and then multiply the sum by 10

- 20 The circle graph below shows the materials in U.S. landfills.

Materials in U.S. Landfills

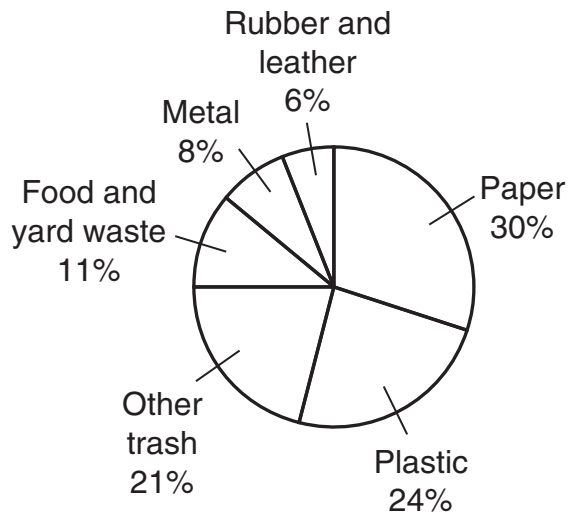

Which of the following statements is NOT supported by the graph?

- F** Paper and other trash make up more than $\frac{1}{2}$ of U.S. landfills.
- G** Rubber and leather and food and yard waste make up $\frac{1}{4}$ of U.S. landfills.
- H** The amount of plastic is triple the amount of metal in U.S. landfills.
- J** The amount of paper is more than twice the amount of metal in U.S. landfills.

- 21 Nora wants to save \$82.50 to buy a special gift for her mother. She has 15 weeks to save the money. If she wants to save the same amount each week, how much money, in dollars and cents, must Nora save each week?

Record your answer and fill in the bubbles on your answer document. Be sure to use the correct place value.

- 22** Randy and his 5 friends played a card game in which the person with the lowest final score wins. The table below shows the final scores for all the players except Erica.

Card Game

Player	Score
Randy	121
Erica	
John	119
Sam	107
Dawn	123
Maya	112

If Erica won the game and the range of the scores was 17, what was Erica's score?

- F** 104
- G** 106
- H** 140
- J** 124

23 A school district hired a speaker to present some information for career day to the middle school students in the district. The speaker used the following information to estimate the total number of students who will attend the presentation.

- There are 3 middle schools.
- There are 20–25 homeroom classes in each middle school.
- There are 25–30 students in each homeroom.

What is the best estimate of the total number of students who will attend the presentation?

- A** 750
- B** 1,125
- C** 1,800
- D** 2,500

24 The data in the table below show the number of lunch items sold at a school snack bar in one day.

Snack Bar

Lunch Item	Number Sold
Slice of pizza	170
Hamburger	80
Nachos	130
Regular milk	200
Chocolate milk	110

Which statement is best supported by these data?

- F** There are a total of 690 students attending classes at the school.
- G** The number of students who bought hamburgers is 50% of the number of students who bought nachos.
- H** There are 300 students at the school who do not like hamburgers.
- J** The number of students who bought chocolate milk is 55% of the number of students who bought regular milk.

- 25 A pest-control company was hired to spray the lawn represented by the shaded region shown below.

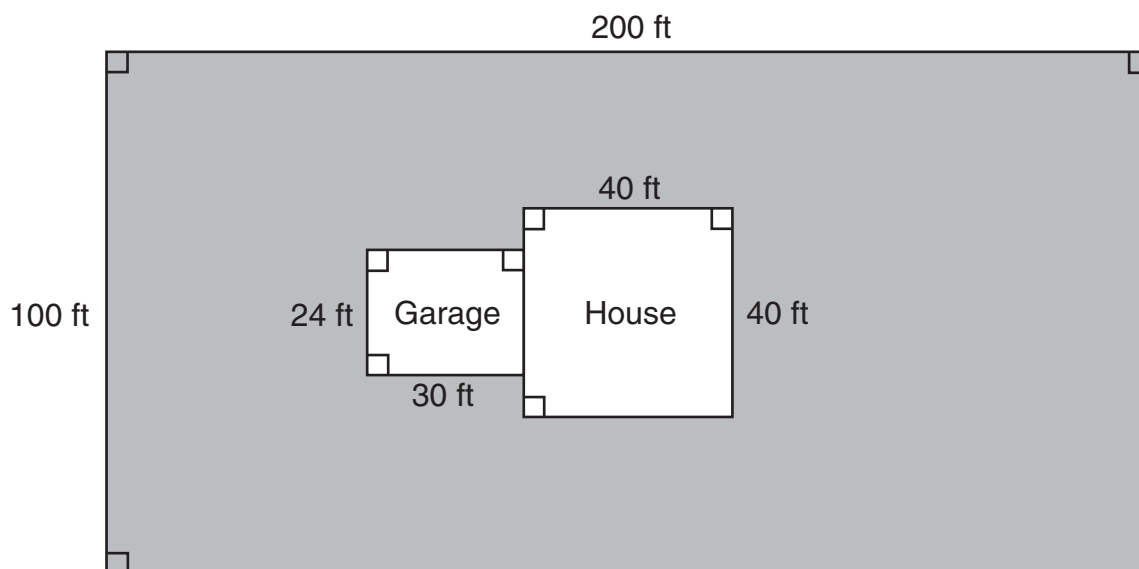

What was the area in square feet that was sprayed?

- A 19,280 ft²
 - B 20,000 ft²
 - C 37,680 ft²
 - D 17,680 ft²
-
- 26 Of the 850 students at Brown Middle School, 38% are in the school band. How many students are in the school band?
- F 32
 - G 527
 - H 323
 - J 812

27 Mrs. Blackburn wrote the following riddle on the board for her mathematics class.

We are 2-digit numbers. Our greatest common factor is 16.
Our difference is 48. Our sum is 112.

What are the 2 numbers of the riddle?

- A 16 and 48, because their greatest common factor is 16
- B 32 and 80, because their difference is 48 and their greatest common factor is 16
- C 16 and 64, because their difference is 48 and their greatest common factor is 16
- D 48 and 96, because their difference is 48

28 For storage Mrs. Lin uses cylindrical containers like the one shown below.

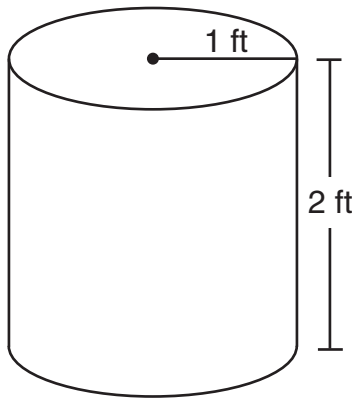

If Mrs. Lin uses 2 of these containers, which is closest to the total volume of both containers?

- F 13 cubic feet
- G 6 cubic feet
- H 8 cubic feet
- J 16 cubic feet

- 29 The table shows several countries and the portion of their population that is under age 15.

Populations

Country	Portion of Population Under Age 15
Chad	47.8%
United States	$\frac{1}{5}$
Uganda	$\frac{1}{2}$
Benin	$\frac{23}{50}$
Ethiopia	47.3%

Which of the following lists the countries in order from least to greatest portion of the population under age 15?

- A United States, Ethiopia, Benin, Chad, Uganda
- B Uganda, United States, Benin, Ethiopia, Chad
- C United States, Benin, Ethiopia, Chad, Uganda
- D Uganda, Chad, Ethiopia, Benin, United States

- 30 Two basketballs can fit inside a hoop, as shown in the drawing below.

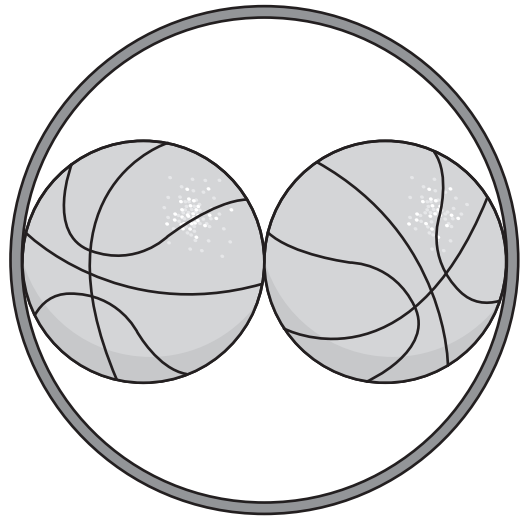

If each basketball has a circumference of 30 inches, which equation could be used to find d , the diameter of the hoop?

F $\frac{30}{\pi} \cdot 2 = d$

G $\frac{30}{\pi} = d$

H $30 = \pi \cdot d \cdot 2$

J $30 \cdot \pi = 2 \cdot d$

31 The table below shows the different sizes of square gardens Charlie can build.

Square Garden Sizes

Garden	Side Length (feet)
W	5
X	10
Y	15
Z	20

Which graph shows the correct relationship between the side length and perimeter of each square garden Charlie can build?

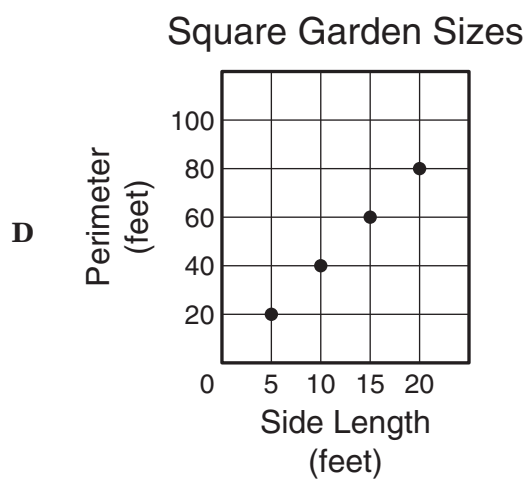
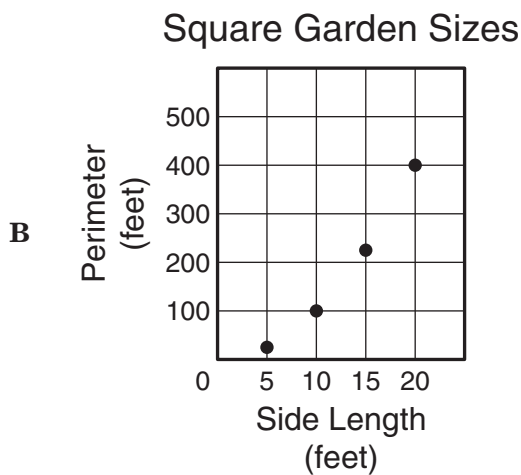
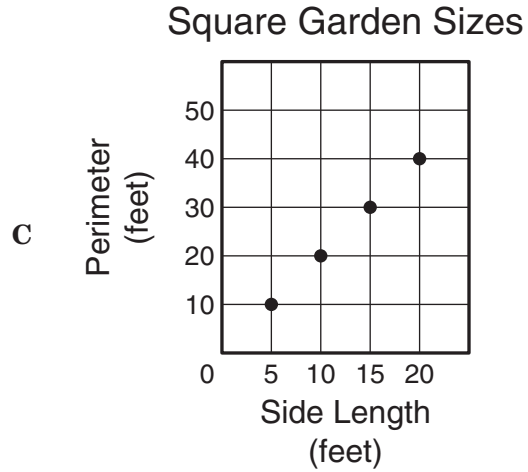
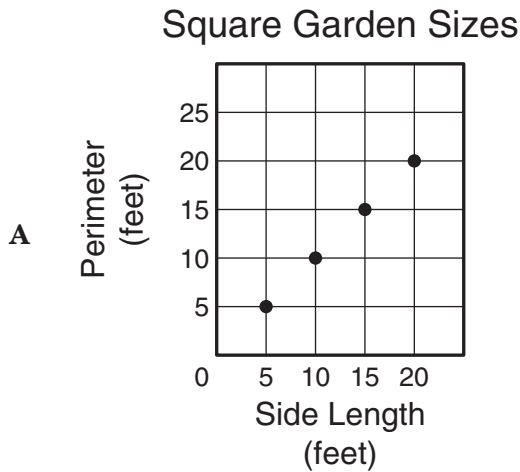

- 32** Stephanie makes cocoa mix to sell at the winter fair. She makes 230 cups of one flavor of cocoa mix and 180 cups of another flavor. To package the cocoa mix, Stephanie needs to purchase containers that hold 2 cups each. The containers are sold in boxes of 50. Which would be the correct order for Stephanie to do the following steps to find the number of boxes of containers she needs to buy?

Step R: Divide the total number of cups of cocoa mix by 2.

Step S: Find the sum of the numbers of cups of the two different types of cocoa mix.

Step T: Divide the number of containers needed by 50 to find the number of boxes of containers to buy.

- F** R, S, T
G S, R, T
H T, R, S
J R, T, S

- 33** Janeska ran in 3 races. The distances she ran in the races were 5 kilometers, 4.25 kilometers, and 5.5 kilometers. How many meters did Janeska run in the 3 races altogether?

- A** 1,475 m
B 14,750 m
C 48,500 m
D 15,000 m

- 34** Bradley answered 80% of the questions on his science test correctly. There were 30 questions on the test, and all the questions had equal value. How many questions did Bradley NOT answer correctly on his test?

- F** 6
G 18
H 24
J 20

- 35** Mrs. Sheldon made lunch for her family. She made tuna sandwiches and chicken sandwiches. She made coconut cookies and oatmeal cookies. Which list shows all possible outcomes if a person picked one sandwich at random and one cookie at random?

- A** (Tuna, coconut), (chicken, oatmeal)
B (Tuna, coconut), (chicken, coconut), (tuna, oatmeal), (chicken, oatmeal)
C (Tuna, chicken), (tuna, coconut), (tuna, oatmeal), (chicken, tuna), (chicken, coconut), (chicken, oatmeal)
D (Tuna, oatmeal), (chicken, oatmeal), (tuna, chicken), (coconut, oatmeal)

- 36 The final project in Yasmeen's art class is to create a 3-dimensional triangular pyramid out of paper. Which net below could Yasmeen use to create a triangular pyramid?

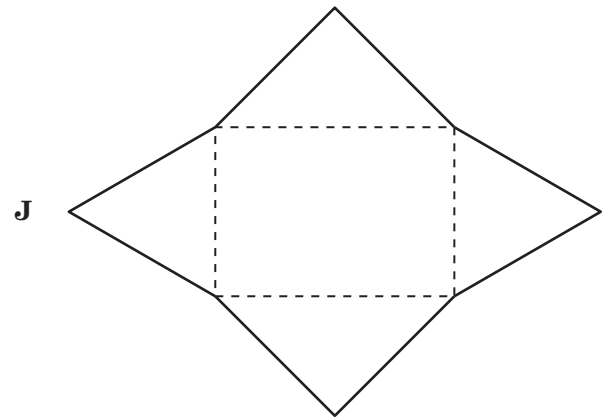
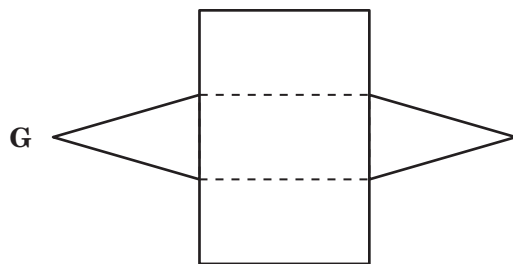
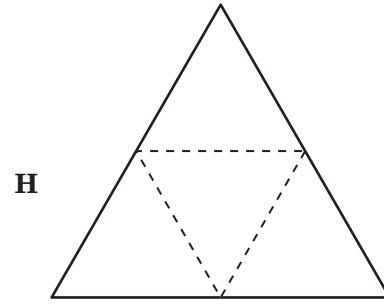
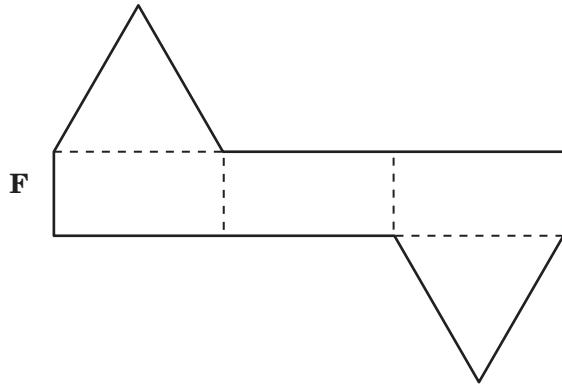

- 37 Which sequence follows the rule $\frac{n}{4}$, in which n represents the position of a term in the sequence?

- A $\frac{1}{4}, \frac{3}{4}, 1, 1\frac{1}{4}, 1\frac{3}{4}, 2\frac{1}{4}, \dots$
- B $\frac{1}{4}, \frac{1}{2}, \frac{3}{4}, 1, 1\frac{1}{4}, 1\frac{1}{2}, \dots$
- C $\frac{1}{4}, \frac{3}{4}, 1\frac{1}{4}, 1\frac{3}{4}, 2\frac{1}{4}, \dots$
- D $\frac{1}{4}, \frac{1}{2}, 1, 1\frac{1}{4}, 1\frac{1}{2}, 2, \dots$

- 38 A newspaper gains and loses subscribers daily, as some people subscribe and other people cancel their subscriptions. The table below shows the subscriptions and cancellations for a newspaper during the first two months of the year.

Subscriptions

Month	New Subscriptions	Cancellations
January	100	30
February	450	120

If the newspaper started the year with s subscriptions, which expression can be used to find how many subscriptions the newspaper had at the end of the two-month period?

- F** $s + 100 + (-30) + 450 + (-120)$
G $s + 100 + 30 + 450 + 120$
H $s + 100 + 450$
J $s + (-30) + (-120)$

- 39 The model below can be used to represent the area of a square with a side length of $\sqrt{25}$ units.

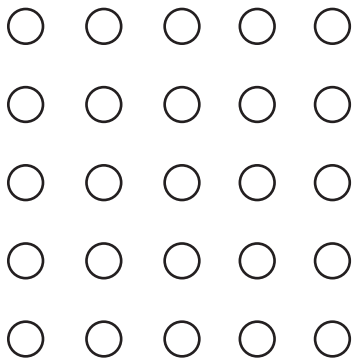

What is another way to represent the side length of this square?

- A** 125
B 5
C $\sqrt{125}$
D $\sqrt{5}$

- 40 Patrice records the number of calories she burns while exercising each day, as shown below.

Day 1: 250 calories

Day 2: 350 calories

Day 3: 400 calories

Day 4: 250 calories

Day 5: 300 calories

How many calories must Patrice burn on the sixth day to have a mean of 300 calories burned for the 6 days?

- F** 0 calories
G 150 calories
H 250 calories
J 310 calories

- 41 Peter wants to find the perimeter of the isosceles trapezoid shown below.

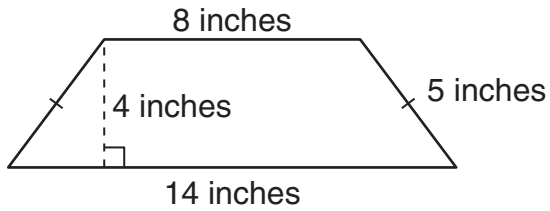

Which equation could Peter use to find P , the perimeter of the trapezoid?

- A $P = 8 \cdot 14 + 5$
- B $P = 8 + 14 + (2 \cdot 5)$
- C $P = (8 + 14) \cdot 4 \div 2$
- D $P = 8 + 5 + 14 + 4$

- 42 The drawing below shows the side view of a picture frame on a desk.

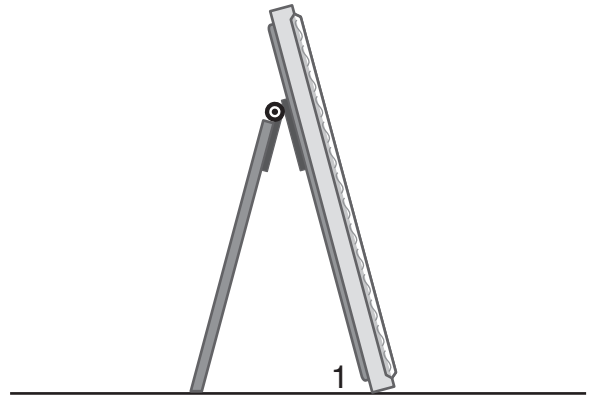

If $m\angle 1$ is 75° , what is the measure of its complementary angle?

- F 15°
- G 25°
- H 105°
- J 115°

43 Lindy is planning to build a model of a train using a scale where 2 inches represents 25 feet. If the train is 60 feet long, what is the length in inches that Lindy should build the model of the train?

- A** 9.6 in.
- B** 2.4 in.
- C** 4.8 in.
- D** 1.2 in.

44 What is the value of the expression below?

$$10 + 7 \cdot 8^2 \div 2$$

- F** 61
- G** 234
- H** 544
- J** 66

45 A 10-ounce box of cereal costs \$2.98, and a 20-ounce box of the same cereal costs \$5.49. Which of these statements will help a shopper decide which box is the better buy?

- A** The 10-ounce box is the better buy because it is less expensive per ounce of cereal.
- B** The 10-ounce box is the better buy because \$2.98 is about \$3, and \$3 goes into \$5.49 about 3 times.
- C** The 20-ounce box is the better buy because it is more expensive per ounce of cereal.
- D** The 20-ounce box is the better buy because two of the 10-ounce boxes cost more than one 20-ounce box.

- 46 Lisa's principal kept a record of the times Lisa's school bus arrived at school. The table below shows the percent of time that the bus arrived on time or was late.

Bus Arrivals

Arrival Times	Percent of Time
On time	40
1 second to 5 minutes late	30
5 minutes 1 second to 10 minutes late	20
More than 10 minutes late	10

Which statement is best supported by the data in the table?

- F The bus was late a higher percent of the time than it was on time.
- G The bus was late less than half the time.
- H The bus was between 1 second and 5 minutes late most of the time.
- J The bus was more than 10 minutes late most of the time.

-
- 47 Ed is reading the math problem shown below.

$$1.6 \overline{)3.2}$$

Which is a correct way to read this problem?

- A One and six tenths divided by three and two tenths
- B Three and two tenths divided by one and six tenths
- C Three and two hundredths divided by one and six hundredths
- D One and six hundredths divided by three and two hundredths

- 48 A survey asked 50 students which activities they like to participate in during the summer. The results of the survey are shown in the table below.

Summer Activities

Type of Activity	Number of Students
Traveling with family	12
Working	13
Visiting friends	25

Which circle graph best represents the data in this table?

Summer Activities

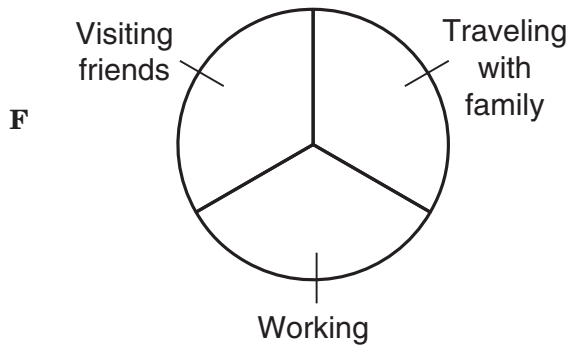

Summer Activities

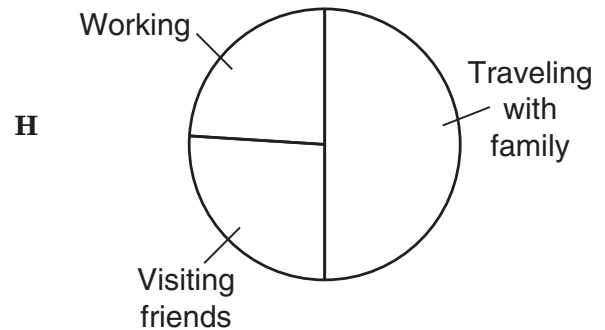

Summer Activities

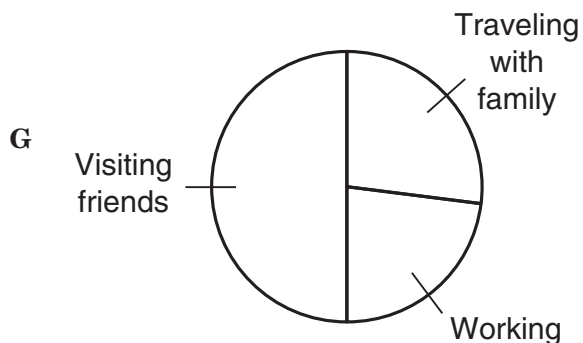

Summer Activities

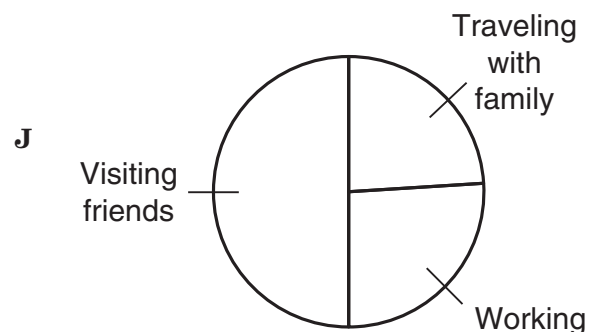

BE SURE YOU HAVE RECORDED ALL OF YOUR ANSWERS
ON THE ANSWER DOCUMENT.



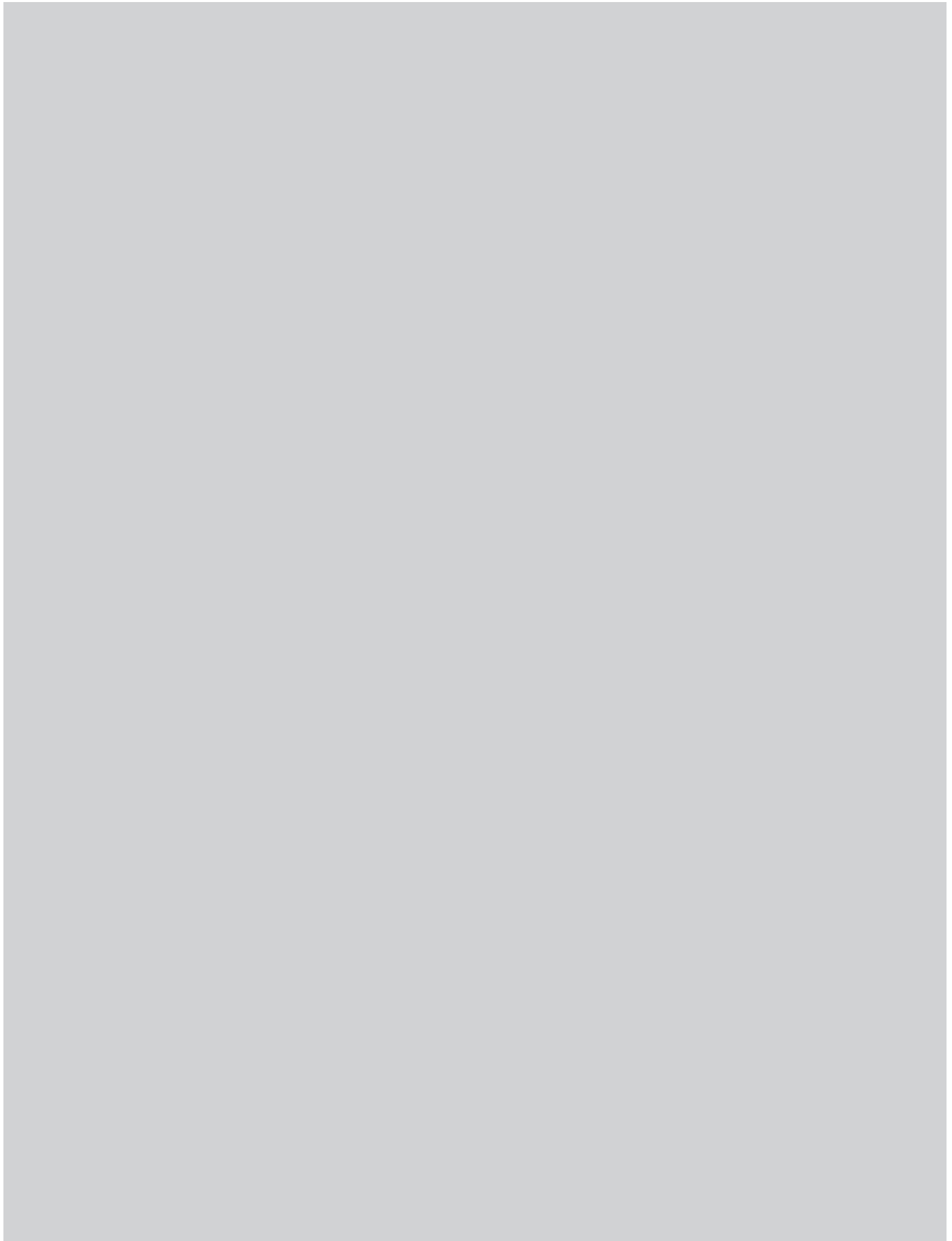

READING

Allison's Gift

- 1 I will never forget the precise moment that caused me to set aside my gift because I wanted the gift that my older sister Carla had.
- 2 My family was spending a week at the beach. One morning, Carla went to the beach early, but I stayed behind to finish a sketch of a seashell I'd found the day before.
- 3 After I finished the drawing, I put on my swimsuit and walked from the hotel to the beach to join Carla. I was about a hundred yards away from the ocean when I spotted Carla doing cartwheels in the wet sand. Lean and muscular, Carla was a champion gymnast. Her motions were slow and fluid, in perfect coordination, as she wheeled along the shore. The beauty of that sight froze me in awe, and I decided instantly that I too would become a gymnast.

My notes about what I am reading

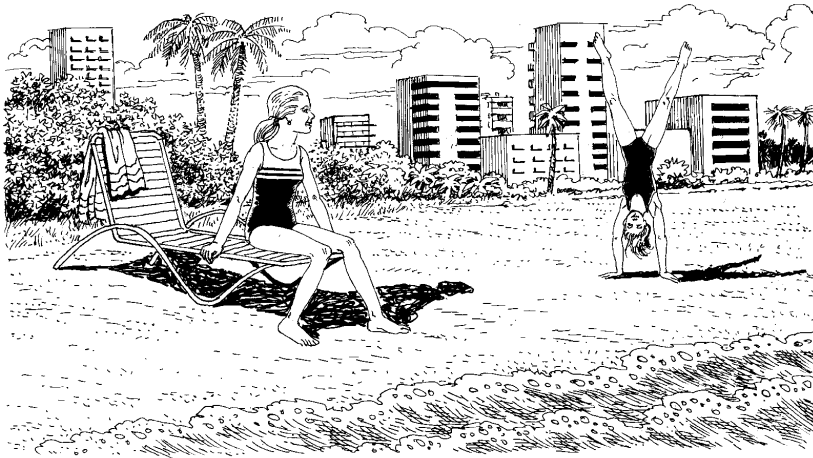

- 4 It is important at this point to mention that I had never been very athletic or particularly agile. Physical education was my least favorite subject in school. Nevertheless, I told my parents I wanted to take a gymnastics class. "O.K., Allison," my mother said with surprise. The next week I enrolled in a beginners' tumbling class.
- 5 If only my parents had talked me out of this misguided plan and spared me the agonies I went through! Five minutes into the first class, it was obvious that I didn't have the makings of a gymnast. I couldn't even master a somersault! But I kept at it.

- 6 During this time drawing and painting—which had been my two passions—all but left my mind. I abandoned art to practice what, in my case, can only loosely be called tumbling. It must have been painful for my family to put on an encouraging face as they watched my dogged but fumbling efforts. I was blindly determined to be like Carla. I just would not give up.
- 7 At some point during this period, on the advice of Ms. Renquist, my art teacher, I hurriedly submitted my seashell sketch for an art contest in our town. One night as I was groaning my way through an attempted back bend in our living room, the phone rang.
- 8 I unbent myself gracelessly as Carla handed the phone to me. It was Ms. Renquist. “You won the contest!” she announced.
- 9 I blinked. “Really?” was all I managed to reply.
- 10 “Yes,” Ms. Renquist said. “They’re going to give you an award at the annual banquet. And that’s not all, Allison. The winner is automatically accepted into Wildale’s Summer Fine Arts Institute.”
- 11 “Wow!” I shouted into the receiver. I couldn’t believe that I’d gotten into such an elite program. Only a handful of young artists were accepted each summer.
- 12 When I hung up, Carla made me recount every word of the conversation. “That’s fantastic, Allison!” she said. “Let’s go tell Mom and Dad.”
- 13 That night I didn’t go back into the living room to continue practicing. And when my tumbling class ended the next week, I didn’t sign up for another session. Gymnastics was Carla’s gift, not mine. It had taken me a while, but I realized that I had a valuable gift of my own.

Mikhail's List

- 1 If you could hear me tell this story aloud, you would know from my accent that I'm not originally from the United States. My family is from Saint Petersburg, a large city in the far western part of Russia. We came to Boston three years ago because my father was invited to teach at a large university in this city.
- 2 Fortunately I already knew English fairly well before we got here. Still, my stomach became knotted up every time I thought about being in an unfamiliar place. For one thing, I would not have a single friend in the United States. For another, as the oldest of three children in my family, I thought I needed to set a good example for my brother and sister and make my parents proud.
- 3 With this weight on my shoulders, I started my new life here. I sat at my desk and made a list of goals for myself.

My notes about what I am
reading

1. *Make one new friend each day.*
2. *Earn the top grades in every subject.*
3. *Be the top athlete in every sport.*
4. *Help my sister and my brother adjust to their new life.*

I taped this list to my bathroom mirror and reread it before leaving for my first day of school in the United States.

- 4 At the time the list seemed entirely reasonable to me. My mother thought otherwise. After reading it, she exclaimed, "Mikhail, you cannot possibly believe that you must accomplish these things! Your father and I don't expect you to be Superman." Maybe they didn't expect me to perform miracles, but I still wanted to excel in every possible way.
- 5 How did I do with the goals on my list? Not so well. First, I did not make a new friend every day, because good

friendships take time. You can't collect friends the way you do baseball cards or marbles. Second, I worked hard but discovered that some subjects were easier for me than others. And that was O.K. Third, in my quest to be

My notes about what I am
reading



incomparable in all sports, I ended up spraining my wrist during a soccer game and breaking an ankle running track. And as for goal number four, I learned that my sister and my brother wanted to live their own life here in the United States, without their older brother's intrusiveness. In fact, they've probably adjusted better than I have. They haven't broken a single bone!

6 So I decided that I needed a new list.

1. Be kind to others.
2. Do my best every day at school.
3. Give my best effort to the sports I love to play.
4. Be a role model for my sister and my brother but learn from them as well.
5. Remember that Superman is a fictional character!

Use “Allison’s Gift” (pp. 60–61) to answer questions 1–5.

- 1** Why are Allison’s parents surprised when Allison wants to take a gymnastics class?
- A** They know Allison has not expressed interest in any kind of physical activity in the past.
 - B** They think it would be easier for Allison to learn gymnastics from her sister.
 - C** They think that she has little time to add another activity to her schedule.
 - D** They know that Allison and her sister do not like to participate in the same activities.
- 2** What is Allison’s main problem in this story?
- F** She cannot find anything that interests her.
 - G** She ignores her own strengths in trying to be like her sister.
 - H** She does not like vacationing with her family.
 - J** She is bothered by her art teacher’s insistence on entering her art in contests.
- 3** In paragraph 3, the author uses the words “froze me in awe” to show that Allison thinks Carla’s gymnastic abilities are —
- A** peculiar
 - B** suspicious
 - C** natural
 - D** dazzling
- 4** What is the tone of paragraph 3?
- F** Jealous
 - G** Bored
 - H** Admiring
 - J** Joyful
- 5** Allison learns to appreciate her own gift when —
- A** she has difficulty practicing back bends in her living room
 - B** she sees her sister doing cartwheels in the sand
 - C** she finds out that she has won an art contest
 - D** she sketches the seashell she found on the beach

Use “Mikhail’s List” (pp. 62–63) to answer questions 6–10.

- 6 Why did Mikhail’s family move to the United States?
- F Mikhail wanted to attend a school where he could play sports.
 - G Mikhail’s father was offered a teaching position at a university.
 - H Mikhail’s family had other relatives living in Boston.
 - J Mikhail needed to improve his English-speaking skills.

- 7 Which idea from the story best shows that Mikhail understands that his original expectations were unrealistic?
- A Mikhail believes he must set a good example.
 - B Mikhail decides to make a new list of goals.
 - C Mikhail realizes that he cannot live his sister’s and brother’s life for them.
 - D Mikhail thinks he will be a disgrace if he doesn’t succeed.

- 8 In paragraph 2, the author uses the words “knotted up” to show Mikhail’s feelings of —
- F anxiety
 - G curiosity
 - H secretiveness
 - J caution

9 Look at the chart of information from the story.

Mikhail's List of Goals	The Result
1. Make one new friend each day.	➔ • _____
2. Earn the top grades in every subject.	➔ • He learns that some subjects are easier for him than others are.
3. Be the top athlete in every sport.	➔ • He hurts himself in two sports.
4. Help my sister and my brother adjust to their new life.	➔ • He finds out they don't need his help.

Which of these belongs on the blank line?

- A He misses his friends back in Russia.
- B He thinks no one wants to be his friend at his new school.
- C He looks for friends who like to collect baseball cards.
- D He realizes that friendships take time to develop.

10 What is one of the main reasons Mikhail sets high expectations for himself?

- F He wants to be a good role model for his siblings.
- G He wants to do as well in his American school as he did in his Russian school.
- H He wants to be one of the most popular people at his school.
- J He wants his parents to compare him to Superman.

**Use “Allison’s Gift” and “Mikhail’s List”
to answer questions 11–14.**

- 11** What are Allison’s and Mikhail’s problems at the beginning of the stories?
- A** Allison’s sister will not help Allison learn gymnastics, and Mikhail’s siblings are eager to help Mikhail achieve his goals.
 - B** Allison does not like being at the beach, and Mikhail is excited about being in a new country.
 - C** Allison ignores her true talent, and Mikhail sets impossible expectations for himself.
 - D** Allison will not ask her sibling for help, and Mikhail feels that he must help his siblings.
- 12** In both selections, use of the first-person point of view allows the authors to —
- F** share each narrator’s inner thoughts and feelings
 - G** concentrate on creating unusual characters
 - H** focus on the most important facts
 - J** describe each story’s setting in vivid detail
- 13** An important theme in both stories is that —
- A** showing concern for others is critical for self-improvement
 - B** facing one’s fears is important in accomplishing goals
 - C** learning to accept oneself is necessary for happiness
 - D** being willing to try new things is the key to success
- 14** How do Allison and Mikhail approach their goals differently?
- F** Allison seeks the help of her parents, while Mikhail ignores what his parents tell him.
 - G** Allison is trying to accomplish something for selfish reasons, while Mikhail is trying to do something that will help others.
 - H** Allison laughs when she makes a mistake, while Mikhail finds it hard to forgive himself when he makes an error.
 - J** Allison focuses on becoming expert at one skill, while Mikhail is trying to excel at many things.

SECTION B1

LOCAL NEWS



The Daily News Dispatch

Thursday, June 29, 1995

Serving the Citizens of West Texas

Gators Roam Downtown Plaza Again

by Wesley Schanen

- 1 EL PASO, Texas—After an absence of more than 20 years, alligators are again the center of attention downtown. But don't worry—these gators are harmless. They are part of artist Luis Jiménez's latest sculpture, titled *Plaza de los Lagartos*, which means "Plaza of the Alligators."
- 2 Hundreds of residents gathered in San Jacinto Plaza to dedicate the large fiberglass statue and fountain. It is located near the area where live alligators once roamed the plaza's pond. The statue brought back fond memories for many who attended the dedication. Some older El Pasoans related stories of childhood visits to the real gator pond in the 1950s and 1960s. Younger residents, however, found it hard to believe that gators actually lived in the park, hundreds of miles from the nearest swamp.
- 3 According to legend, the whole thing started as a joke. Around 1883 an El Paso miner named Adolph Munsenberger received a package about the size of a shoe

box from a friend in Louisiana. Inside he found six baby alligators along with a note from his friend. The note suggested that Munsenberger use the alligators to haul mining carts. By all accounts Munsenberger took the joke well. He put the little reptiles into a water barrel and began raising them as pets. However, he knew that this small home could be only temporary. Munsenberger went to the mayor and offered the gators as a gift to the city. The mayor accepted even though there wasn't really a place to keep the animals. He finally decided to put the gators in the recently completed pond in San Jacinto Plaza.

4 El Paso residents soon began to think of the gators as community pets. They gave each gator a name—Humpy, Sally, Ally, Don Porfirio, Mimmie, and Abercrombie. The gators quickly became local celebrities. El Paso newspapers reported their activities as though they were respected citizens. News accounts detailed the latest gator facts, and gossip columns included gator rumors. One local newspaper even ran a weekly column called "Alligators' Tails." The column

■ see Gators Roam, page 2

related the “true” history of how alligators came to El Paso, as told by one of the alligators. People throughout the city shared tall tales and anecdotes about their unusual new neighbors. As these tales spread, each gator seemed to take on a unique personality. For example, witnesses claimed that Ally liked music. They said that he would wag his tail whenever a mariachi band performed in the park.

5 Alligators occupied the pond in San Jacinto Plaza for some 80 years. Over the years the original alligators died and were replaced with new ones. The alligators remained a popular local attraction and could be seen sunning themselves during the warmer months. Although El Paso is usually warm and sunny, its winters were cold for the gators. When temperatures dropped, usually in late October, the gators would retreat to the center of the pond. They would remain there in a type of hibernation until warmer days returned. Around March the gators would crawl back out of the water. Many El Pasoans came to view the alligators’ reappearance as a sure sign of spring.

6 Of course, the gators were by nature dangerous animals. On a few occasions park workers were attacked. Although most El Pasoans were fond of the alligators, people often involved the gators in risky pranks and practical jokes. On at least one occasion, a gator was placed in a hotel room to welcome an unsuspecting tourist. Once, students from a local college kidnapped one of the large reptiles and put it in the school swimming pool. Some of these exploits were even more harmful. There were incidents in which the alligators were mistreated and abused. In the 1960s two alligators were stoned to



The *Plaza de los Lagartos* sculpture was dedicated yesterday.

death, and another lost an eye. Park officials became worried about the gators’ safety and wisely decided to move them to the city zoo. Though the gators made a brief return to the pond in the 1970s, protected by a plastic enclosure, the zoo eventually became their permanent home.

7 After they left San Jacinto Plaza, the gators gradually faded into El Paso’s past. Then in 1987 city officials asked Jiménez to create a work of art for downtown El Paso. An El Paso native, Jiménez remembered seeing the gators as a boy. He knew that they held special memories for many El Pasoans and chose to make them the subject of the statue. The statue took Jiménez eight years to complete. It depicts four alligators seeming to lunge out from the fountain, two with their mouths agape, their sharp teeth bared as if ready to attack. Mist from the fountain keeps the gators looking moist and lifelike. Those in attendance at the dedication were happy that the park’s most famous citizens had finally returned—at least in spirit—to San Jacinto Plaza.

Photograph courtesy of © Maria Gallegos.

15 Read the diagram of information from the article.

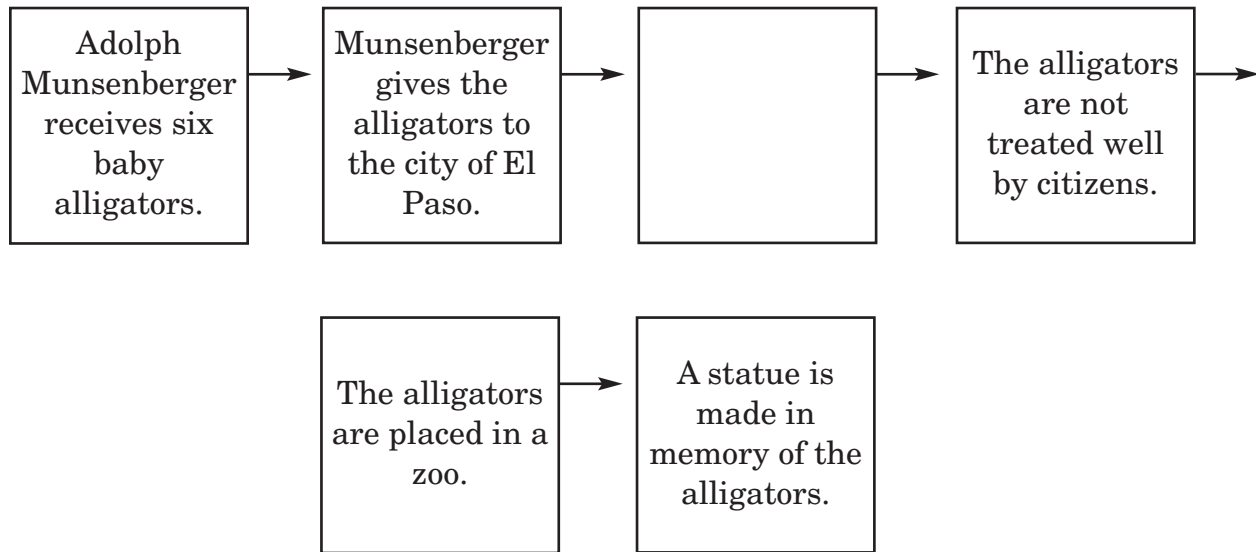

Which of the following belongs in the empty box?

- A Two alligators are stoned to death.
- B The alligators are protected by a plastic enclosure.
- C The alligators are brought back to El Paso for a brief time.
- D The alligators are considered community pets.

16 The first alligators were originally sent to El Paso —

- F as a gift to the city
- G to be community pets
- H to welcome tourists
- J as part of a joke

17 Which sentence from this article supports the idea that many people in El Paso still think of the alligators as special?

- A *Munsenberger went to the mayor and offered the gators as a gift to the city.*
- B *An El Paso native, Jiménez remembered seeing the gators as a boy.*
- C *The statue brought back fond memories for many who attended the dedication.*
- D *Many El Pasoans came to view the alligators' reappearance as a sure sign of spring.*

- 18 What is paragraph 6 mainly about?
- F How the alligators were used to scare tourists
 - G Why El Pasoans thought the alligators were harmful
 - H Two alligators that were killed in the 1960s
 - J Why the alligators had to be moved to the zoo

- 19 Which sentence from this article supports the idea that it would be unusual to find alligators living in El Paso?
- A *Hundreds of residents gathered in San Jacinto Plaza to dedicate the large fiberglass statue and fountain.*
 - B *Younger residents, however, found it hard to believe that gators actually lived in the park, hundreds of miles from the nearest swamp.*
 - C *El Paso newspapers reported their activities as though they were respected citizens.*
 - D *Alligators occupied the pond in San Jacinto Plaza for some 80 years.*

- 20 From information in this article, the reader can conclude that El Paso —
- F had many other parks with alligator ponds
 - G did not have a zoo when Adolph Munsenberger received the alligators
 - H did not have any fountains when city officials contacted Luis Jiménez
 - J wanted the alligators to be returned to Louisiana

- 21 The tone in paragraph 4 can be described as —
- A humorous
 - B embarrassed
 - C curious
 - D doubtful

- 22** Read this part of an outline of information from the article.

I. Reasons the alligators were moved to the zoo

A. _____

B. Mistreated and abused

C. Dangerous to people

Which idea belongs on the blank line?

F Used for pranks

G Cold winter temperatures

H Seen as pets

J Grew too large

- 23** What does the word agape mean in paragraph 7?

A Damp

B Full

C Open

D Shiny

- 24** Why does the author include information about the real alligators that once lived in the plaza?

F To persuade readers to visit the alligator statue in El Paso

G To educate readers about the dangers the alligators faced

H To give information about alligators in Texas

J To show how the statue relates to the city's history

Home Sweet Catalog Home

- 1 In 1925, the year I turned 13, a Sears catalog changed my life. Up until then my family had rented a tiny three-room apartment on Main Street. My three brothers slept in the bedroom with my parents. My younger sister and I slept on a foldaway sofa in the living room. Daddy didn't make much money as a coal miner, so having our own house seemed like an impossible dream—that is, until the day the Sears *Modern Homes* catalog came in the mail. Daddy had ordered the catalog and paid a whole dollar for it. Mama wasn't too happy about his spending so extravagantly on a catalog, but Daddy said it was worth every penny.
- 2 The catalog showed the different houses that could be built from a Sears do-it-yourself home kit. The kit came with everything a family needed to build its very own house. There were blueprints and a book of instructions that showed how to build the house, as well as all the wood, nails, paint, roofing, and so on. Each house had a different name, such as the Salem or the Woodland. Some of the houses were big and some small, but they were all beautiful. It didn't seem possible that we could ever have a home like one of those.
- 3 Mama thought Daddy was just dreaming. She looked at the catalog over his shoulder. "John, that house costs more than a thousand dollars!" Mama exclaimed. "We can't afford that."
- 4 "There are cheaper houses in here," Daddy said, flipping to a different page and contemplating the features of another house. "Look! Here's one that starts around \$600—the Estes." He put the catalog down and looked at my mother. "Grace, you know no bank will give us a loan so we can get our own place. But we can do it if you get a job to help make the extra money."

My notes about what I am
reading

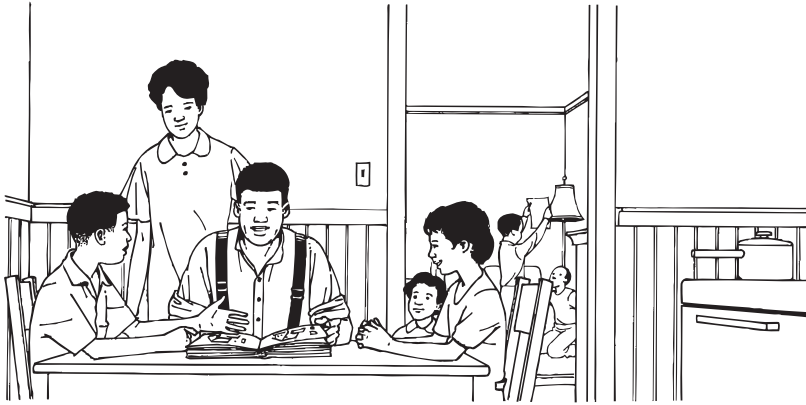

- 5 Mama still looked doubtful. It took a while, but Daddy finally wore down Mama's resistance. Mama found a job as a seamstress, sewing clothes for people. She was able to work from home, so she could still take care of the little ones. I even started collecting soda bottles to make money. After several months we used our family's small savings to buy a piece of land outside town. Then we all studied the catalog until we just about knew it by heart. We finally decided to order a house called the Solace. It had not one, not two, but *three* bedrooms—one for my parents, one for the boys, and one for us girls!
- 6 Finally the big day came. Our kit arrived at the train station, and we had to go pick it up. Daddy borrowed a wagon and two horses to pull the kit. Then he, my older brother Peter, and I rode to the station together. I had read in the catalog that each home kit contained 30,000 pieces, but it didn't really sink in until I saw how enormous our shipment was. Again and again we loaded the wagon with the pieces we would use to build our house. Again and again we made the trip between the train station and our land. How my arms ached from loading and unloading that wagon!
- 7 During the weeks before our house arrived, on Daddy's days off, he and my oldest brother had dug and laid the foundation for the house. The day after our shipment came, we all started to build the frame. Daddy called this the bones of the house—the pieces of wood that would later be covered by the walls and the roof. It was hard work, but Daddy's excitement was contagious. Even the little kids helped out by sorting the materials. Sears had told the truth—the kit contained everything we needed to build our dream house, including doorknobs, windowpanes, and flooring.

- 8 Every minute that Daddy wasn't working in the mines was spent working on our house. Every day our dream was slowly becoming a reality. Mama was talking about where she would hang the curtains she was making with the material left over from her sewing jobs.
- 9 Then disaster struck. Daddy became sick with a bad cold that turned into pneumonia. The doctor told us that Daddy had to stay in bed and that it could take him weeks, even months, to get better. Daddy was too sick to argue. The sound of his coughing filled our apartment. Meanwhile, five miles away, our house stood unfinished. It was September, and the days were getting shorter and colder. I knew how badly Daddy had wanted to finish the house before winter, but that seemed unlikely now. Our hopes of ever finishing it started to fade.
- 10 One afternoon when Daddy was sleeping, Mama gathered all of us together. There was an obstinate look on her face. I had seen this look before, when Mama had her mind set on something, and I knew that nothing was going to stand in her way. "I've been reading the directions Sears sent," she said in a firm voice, "and we are going to finish our house." It was Mama's turn to take over.
- 11 We were surprised, but we weren't about to argue. Whenever she could, Mama would go to the house and work. She would tell Daddy she was running errands or taking the younger kids out to the park so that he could get his rest. As soon as school was out for the day, my older brother and I would go straight to the house. We built and painted walls. We laid down pine floors. We even put black tar paper on the roof to waterproof it and covered that with shingles. Sometimes Mama got a friend or neighbor to help, but she and my brothers and sister and I did most of the work. The best part was that Daddy didn't know what we were up to. Several weeks later, when he was feeling much better, he got the surprise of his life. As we all stood inside our new home and looked around, Daddy's face had the biggest smile I have ever seen.

- 25** This story is organized by —
- A** comparing a family’s life in an apartment with its life in a house
 - B** describing a series of events that fulfills a family dream
 - C** discussing what each member of a family thinks about building a home
 - D** providing examples of how people lived in 1925

- 26** The author includes the information in paragraph 9 to —
- F** show what kind of relationship the narrator has with her father
 - G** illustrate how Mama’s feelings about the house have changed
 - H** create suspense about whether the family will ever have its own house
 - J** explain how to recognize and treat the symptoms of pneumonia

- 27** Based on information in the story, what can the reader conclude about the year 1925?
- A** Most people lived in houses built from kits.
 - B** Catalogs were seen as luxury items.
 - C** A dollar was considered a lot of money.
 - D** Many men worked as coal miners.

28 Which of the following is the best summary of the story?

- F The father of a large family orders a catalog offering kits for building a house. The mother of the family thinks he is just dreaming and says that the kits are too expensive. But in time the father convinces her that buying a house kit is a good idea. The mother gets a job as a seamstress, and all the family members work hard to save money for land and a kit.
- G The father of a large family living in a small apartment wants to buy a house kit from a catalog so that the family can build its own house. With everyone working together, the family members save money, buy land, order a house, and start building. When the father gets sick and can't work on the house, the mother and the children take over and work to finish it.
- H After a man orders a catalog, his family looks through it. The family decides to buy a kit for a house called the Solace. The house kit that arrives by train contains everything the family needs to build its own home. There are 30,000 pieces, including nails, wood, paint, roofing, doorknobs, windowpanes, and floors.
- J The members of a large family decide to buy a kit to build their own home. The family starts to build a house, but disaster strikes when the father gets sick with pneumonia. The mother of the family reads the directions that came with the house and tells the children that she wants to finish it.

29 To the family the catalog is a symbol of —

- A wealth
- B freedom
- C strength
- D hope

30 Read this phrase from paragraph 9.

the days were getting shorter and colder

The author uses these words to create a feeling of —

- F hope
- G relief
- H suspicion
- J discouragement

31 Which sentence from the story shows that the narrator's father is a source of strength for the rest of the family?

- A *It was hard work, but Daddy's excitement was contagious.*
- B *Daddy called this the bones of the house—the pieces of wood that would later be covered by the walls and the roof.*
- C *It took a while, but Daddy finally wore down Mama's resistance.*
- D *Our hopes of ever finishing it started to fade.*

- 32** Which idea from the story shows how different life in 1925 was from the way it is today?
- F** The narrator’s mother disapproves of the narrator’s father wasting money.
 - G** The narrator and her family live in a small apartment.
 - H** The narrator, her father, and her brother ride to the train station in a wagon.
 - J** The narrator’s father takes a long time to recover from pneumonia.

- 33** Why does the author choose to tell this story from a first-person point of view?
- A** To help the reader better understand the emotions the family experiences
 - B** To show how families react in the face of tragedy
 - C** To help the reader know what it was like to be 13 years old in 1925
 - D** To show how children react to a parent’s illness

- 34** The family members solve the problem of having enough money to order a house by —
- F** working together to earn what they need
 - G** deciding to order the cheapest house in the catalog
 - H** taking their savings out of the bank
 - J** deciding to sell their apartment

- 35** In paragraph 10, the word obstinate means —
- A** gentle
 - B** selfish
 - C** stubborn
 - D** humorous

- 36** The author wrote this story most likely to —
- F** show how a family’s life changes because of a catalog
 - G** inform readers how to build a house from a kit
 - H** explain how family members can work together to save money for a house
 - J** compare life in 1925 with life today

Baby Stephen

- 1 He was my baby. When I held him in my arms, I couldn't believe how cute he looked. I almost believed he was real.
- 2 The babies were actually plastic, with little computer chips implanted in their backs. Mrs. García, our health teacher, wanted us to learn about the responsibilities of having a real baby, so she arranged for a learning lab for our class. Our assignment was to take care of a computerized baby for 48 hours. First we watched a video about caring for babies and then signed a paper promising that we wouldn't leave the baby by itself. I had no problem with signing the paper, since I knew that I was going to be a great dad—maybe the most attentive dad that baby Stephen would ever have!
- 3 For a while everything was fine. I was laughing and walking around the school, bragging that my kid was obviously the best-looking baby. Then as soon as I walked into English class, Stephen started to shake and cry. Boy, was he loud! I thought my ears were going to burst. I was looking around for someone to hand him to when I realized he was *my* responsibility for the next 48 hours. That seemed like forever and a day.
- 4 My baby was the only one crying. Everyone was pointing and snickering. "Stephen, please stop crying," I kept saying, forgetting that he was just made out of plastic. I had no idea how to pacify him.
- 5 I thought about the video. It's a lot easier to remember when you're watching a videotape than it is when you're holding a shrieking, squirming baby in front of the whole class. "First I'm supposed to . . ." I mumbled. "Oh yeah! I have to check the diaper." Everybody laughed, but I felt a little better when two other babies started to cry.
- 6 "Victor," my English teacher Mr. Klecko said, "take the diaper off, and once the metal contacts—"
- 7 I said to Stephen, "Would you please stop crying for two seconds? I can't hear the teacher."
- 8 "When you take the metal contacts away from Stephen's body," Mr. Klecko continued in a louder voice, "then he'll

My notes about what I am
reading

stop crying if he's been programmed to cry because of wetness."

9 But that wasn't the problem. I thought my eardrums were going to bounce out of my head. "Oh man," I said, "this kid has a great set of plastic lungs!"

10 Mr. Klecko smiled at me and said, "So, Victor, what's next?"

11 "Maybe he's hungry," I said. I dug through the baby bag and found the bottle with the metal end. I knew that if I touched the bottle to the contact on the baby's lips, he might stop that awful crying.

12 But that didn't work either.

13 By this time there were several other computerized babies screaming in our classroom and other panicked 12-year-olds trying to figure out what to do with them. My buddy Ralph placed his baby on its back on the desk. Stepping back, he held his hands over his ears as if his head were about to explode. Felicia was also trying to feed her baby, but it was still screaming like something out of a horror movie. The only one who wasn't flustered was Katrina. She was going through the procedures as if she'd taken care of a baby a million times before. I finally realized that this was probably true, since she had a baby sister at home.

14 "No fair," I thought. "She's had practice!"

15 "Victor?" Mr. Klecko's voice brought me back to my own problems. "What's the next thing you should check?"

16 As I watched Katrina, I remembered the third thing. I placed Stephen on my shoulder and began rocking him and patting his back. Stephen slowed down his screaming and began to whimper. Then he burped. I held him away from me and looked at him. He made this little cooing noise, and then he actually laughed. It was this cute little baby giggle. It was great! I was proud of Stephen. He was the first baby to cry and the first baby to burp!

17 I have to admit that the rest of the day was even harder. Since my class was the first to try the new baby experiment, my friends from other classes teased me every chance they could. In the halls they would point and laugh as I walked with Stephen in my arms. At lunch they made cooing noises at me and asked me whether I needed a bottle, too. "Just wait until it's your turn," I kept thinking.



- 18 That night I watched TV, ate dinner, did math homework, and got ready for bed. All the while I had to hold Stephen. It was nearly impossible to do these things while holding him. Of course, my parents gave me a million suggestions on how to take care of Stephen. Even though I knew they were trying to be helpful, they actually made me feel like a baby myself. As soon as Stephen was finally asleep, I threw myself onto my bed. Sleep had never sounded so good.
- 19 I had slept for only three hours when Stephen woke me up with his yelling. After feeding him, I tried to get back to sleep. That's when he started it again. Didn't he know it was 2:13 in the morning? This time he needed to have his diaper changed.
- 20 At 3:46 he wanted to eat again.
- 21 At 5:22 he needed to be changed, fed, and burped.
- 22 The next morning I sat in Mrs. García's room and just stared into space as everyone else talked about their babies. Ralph's baby woke him up 11 times. Katrina's, of course, had slept straight through the night.
- 23 Just when my head was sinking to my desk, Stephen started crying again. Wearily I checked his diaper and then rummaged in the bag for his bottle. I could tell this was going to be the longest day of my life.

- 37** When Victor receives the computerized baby, he feels —
- A** thankful for Mr. Klecko's help
 - B** angry that his friends won't stop teasing him
 - C** capable of caring for Stephen
 - D** frustrated with the assignment

- 38** Why does Victor say his parents make him feel like a baby?
- F** They tell him how to take care of Stephen.
 - G** They won't let him hold Stephen.
 - H** They think he will not do his assignment.
 - J** They tell him to go to bed early.

- 39** In paragraph 2, what does the word implanted mean?
- A** Loud
 - B** Inserted
 - C** Floating
 - D** Designed

40 Which of these is the best summary of the story?

- F** All the students in Victor’s health class are given a computerized baby to take care of. At first Victor enjoys caring for his baby Stephen. However, when Stephen begins to cry loudly in English class, Victor does not know what to do. Throughout the day Victor has to deal with teasing from his friends and unwanted advice from his parents. Stephen cries off and on all that night and starts again the next morning during Victor’s class.
- G** Victor is given a computerized baby to take care of for 48 hours. His baby is named Stephen. When Stephen begins to cry, Victor does not remember how to comfort him and must be reminded what to do by his English teacher, Mr. Klecko. At lunch Victor’s friends tease him, and at home his parents give him suggestions he doesn’t want.
- H** A few students in Victor’s school are given computerized babies to take care of for 48 hours. Katrina, who has a baby sister at home, does a good job caring for her baby. Other students, such as Victor’s friend Ralph, have no idea how to stop a baby from crying. Victor does not leave Stephen’s side all day.
- J** Victor feels tired after taking care of Stephen, his computerized baby, especially after doing his homework and eating dinner while holding Stephen. The next morning in his health class, the students are talking about their babies, but Victor just sits at his desk staring into space until it is time to check Stephen’s diaper and give him another bottle.

41 Paragraph 13 is mostly about —

- A** the different ways students try to quiet their babies
- B** how good Katrina is with her baby
- C** how envious Victor is of Katrina
- D** why the video’s suggestions do not work

42 Which idea from the story shows that other teachers know about the baby experiment that Victor’s health class is conducting?

- F** Victor has to sign a paper promising he will not leave baby Stephen alone.
- G** Victor’s English teacher tells him about the metal contacts.
- H** Victor knows his friends will all have to participate in the baby experiment eventually.
- J** Victor’s teachers give the students homework that is related to baby care.

- 43 In paragraph 5, which words does the author use to create a sense of frustration?
- A *a lot easier to remember*
 - B *I felt a little better*
 - C *a shrieking, squirming baby*
 - D *Everybody laughed*
- 44 The reader can conclude that as the second day unfolds, Victor will —
- F have his parents take care of Stephen for a little while
 - G come up with a way to make Stephen sleep
 - H become more tired until it is time to give Stephen back
 - J try to persuade Katrina to trade babies with him
- 45 Which statement best describes Victor’s feelings about taking care of Stephen?
- A He thinks of this assignment as no different from any other.
 - B He grows more unsure of his ability to quiet Stephen.
 - C He realizes that he should listen to his parents’ suggestions.
 - D He finds it more difficult than he expected.
- 46 In paragraph 13, the author uses the phrase “like something out of a horror movie” to —
- F emphasize how disturbing the noise is
 - G describe Felicia’s feelings about the project
 - H explain why the baby is crying
 - J compare Katrina’s and Felicia’s behavior
- 47 Victor realizes how exhausting a baby can be when —
- A he has to carry Stephen all day at school
 - B Mr. Klecko tells him what he should do in class
 - C he remembers all the video’s instructions on how to take care of a baby
 - D Stephen cries throughout the night
- 48 How has Victor changed by the end of the story?
- F He decides to break his promise not to leave Stephen alone.
 - G He thinks Stephen is more advanced than the other babies.
 - H He is learning how to take care of Stephen.
 - J He realizes he is better at caring for a baby than Katrina is.

BE SURE YOU HAVE RECORDED ALL OF YOUR ANSWERS
ON THE ANSWER DOCUMENT.



